

MODEL DV52

5.0 HP VACUUM SYSTEM

LARGE, EASY ACCESS
FILTER SERVICE DOOR

SUPER EFFICIENT
FILTRATION

FILTER CONDITION
INDICATOR GAUGE

EFFECTIVE
FILTER BAG
SHAKER

FILTERS NEVER
NEED CLEANING
AS THE CANISTER
FILLS.

OPTIONAL HEPA
FILTER WITH
CONDITION
INDICATOR

OVERHEAD
CRANE LIFT
HOOKS

2.5" NPT
INLET WITH
INTERNAL
WEAR STRIP

19.3 US GAL
STORAGE DRUM

OPTIONAL EQUALIZER
KIT ALLOWS GARBAGE BAG
LINER IN DRUM

SIX (6) FILTER BAGS WITH
20.9 SQ FT FILTER AREA

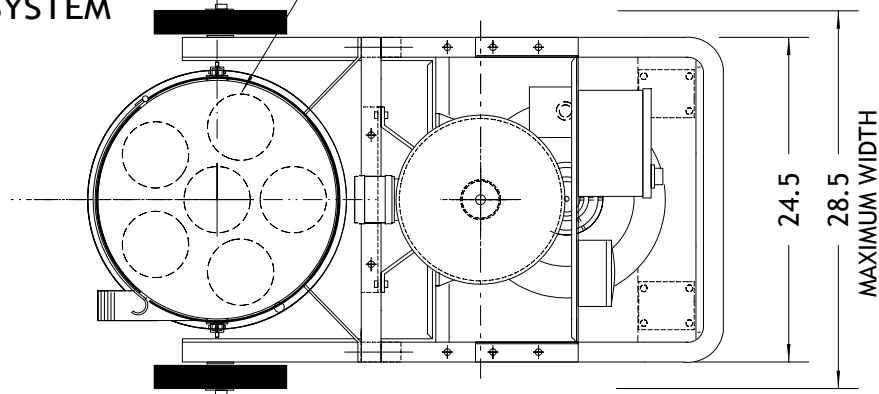

18" DIAMETER
BAGHOUSE FILTER

SPECIFICATIONS:

5.0 HP MOTOR (VOLTAGE TO SUIT)
219 SCFM MAX
113" STATIC PRESSURE MAX
20.9 SF FILTER BAGS
99.997% @ 0.4 MICRON EFFICIENT
19.3 US GALLON STORAGE DRUM
75 dBa NOISE LEVEL
WEIGHT 426 LBS

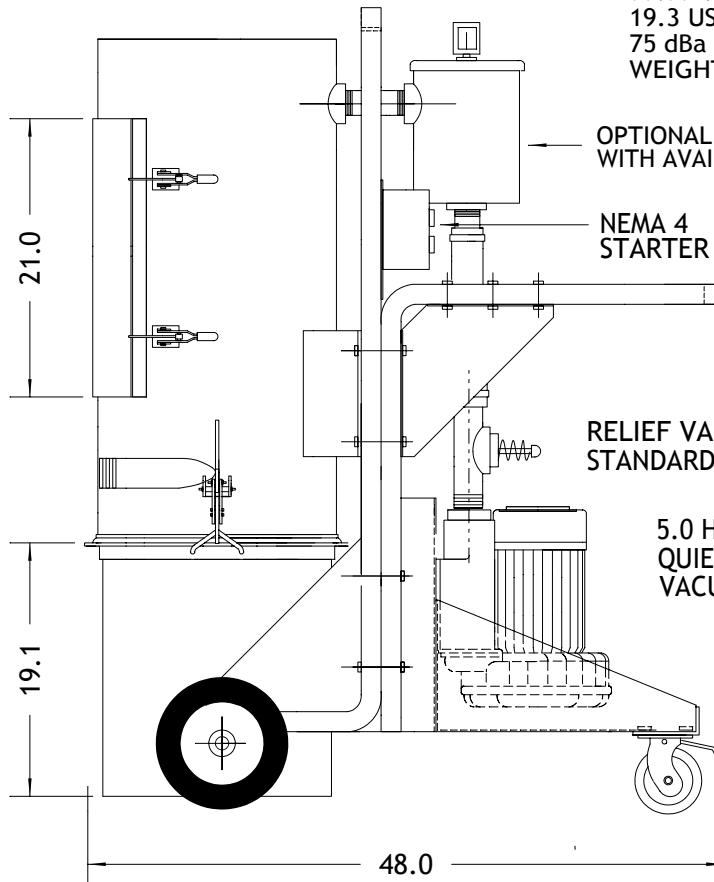

OPTIONAL INLINE FILTER
WITH AVAILABLE HEPA UPGRADE

NEMA 4
STARTER SWITCH

RELIEF VALVE
STANDARD

5.0 HP
QUIET, DEPENDABLE
VACUUM PRODUCER

EFFECTIVE, BUILT-IN
SILENCER

LOCKABLE
5" SWIVEL CASTERS

			DATE:	FEB 2004	NORTHWIND AIR SYSTEMS BRAMPTON, ONTARIO
			DRAWN BY:	KRW	
			SCALE:	N.T.S.	
0	APR 04	ISSUED FOR REVIEW	DRAWING No.	Rev.	DuroVac DV52 CONTINUOUS DUTY VACUUM SYSTEM
No.	DATE	REVISIONS	DVD20402	00	