

# MODEL DV52c

## 5.0 HP VACUUM SYSTEM

LARGE, EASY ACCESS  
FILTER SERVICE DOOR

SUPER EFFICIENT  
FILTRATION

FILTER CONDITION  
INDICATOR GAUGE

EFFECTIVE  
FILTER BAG  
SHAKER

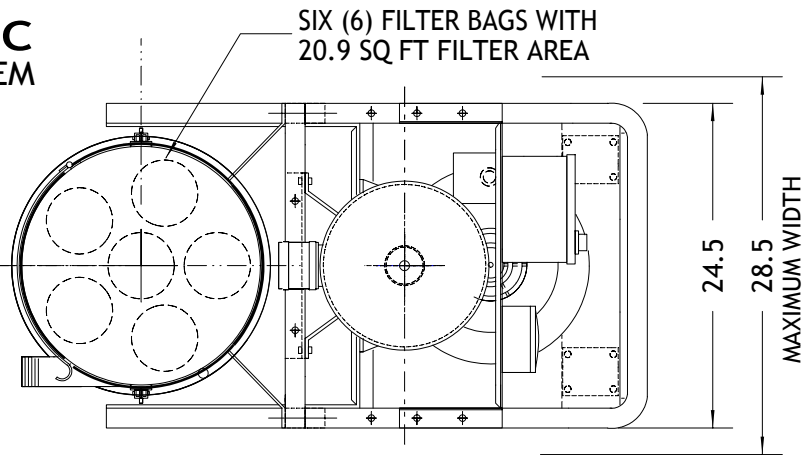

### SPECIFICATIONS:

5.0 HP MOTOR (VOLTAGE TO SUIT)  
219 SCFM MAX  
113" STATIC PRESSURE MAX  
20.9 SF FILTER BAGS  
99.997% @ 0.4 MICRON EFFICIENT  
19.3 US GALLON STORAGE DRUM  
75 dBa NOISE LEVEL  
WEIGHT 426 LBS

18" DIAMETER  
BAGHOUSE FILTER

FILTERS NEVER  
NEED CLEANING  
AS THE CANISTER  
FILLS.

OPTIONAL HEPA  
FILTER WITH  
CONDITION  
INDICATOR

2.5" NPT  
INLET WITH  
INTERNAL  
WEAR STRIP

19.3 US GAL  
STORAGE DRUM

OPTIONAL EQUALIZER  
KIT ALLOWS GARBAGE BAG  
LINER IN DRUM

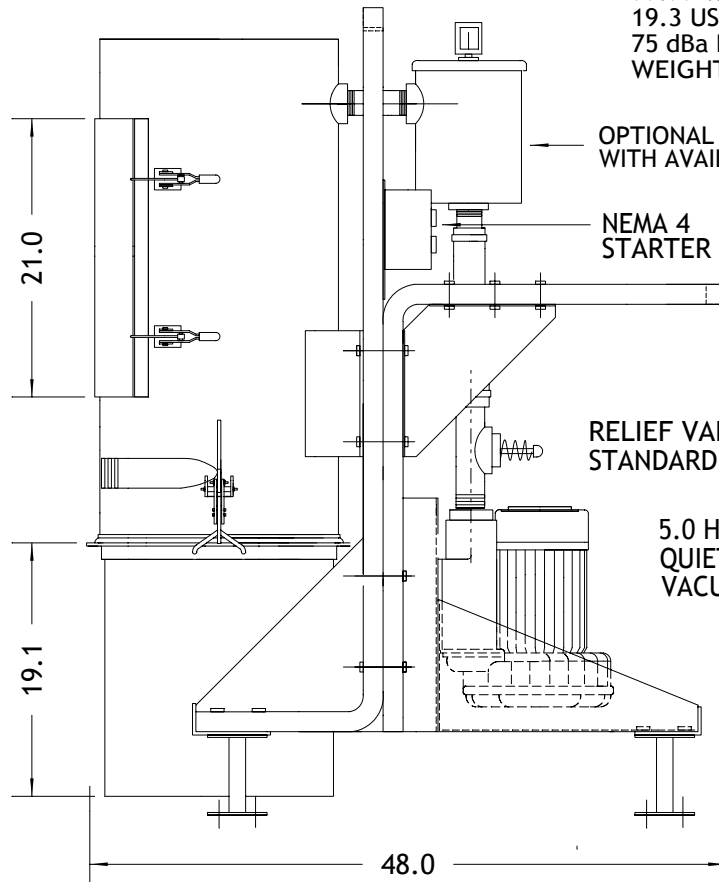

EFFECTIVE, BUILT-IN  
SILENCER

			DATE:	FEB 2004	NORTHWIND AIR SYSTEMS BRAMPTON, ONTARIO
			DRAWN BY:	KRW	
			SCALE:	N.T.S.	
0	FEB 04	ISSUED FOR REVIEW	DRAWING No.	Rev.	<b>DuroVac</b> <b>DV52c</b> CONTINUOUS DUTY VACUUM SYSTEM
No.	DATE	REVISIONS	<b>DVD20406</b>	<b>00</b>	