

# MODEL DVR8553c

## 8.5 HP CENTRAL VACUUM

LARGE, EASY ACCESS  
FILTER SERVICE DOOR

SUPER EFFICIENT  
FILTRATION

FILTER CONDITION  
INDICATOR GAUGE

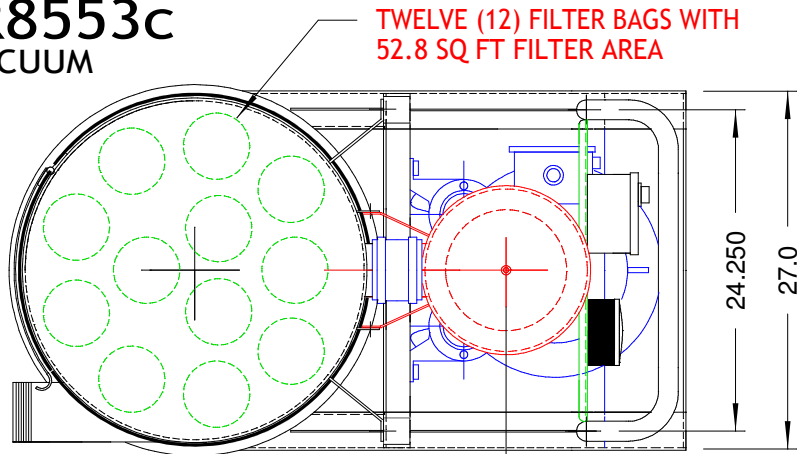

TWELVE (12) FILTER BAGS WITH  
52.8 SQ FT FILTER AREA

BOLT DOWN PATTERN:  
28.625" LENGTH  
24.250" W AT TANK  
17.250" W AT REAR  
9/16" HOLE DIAM. (TYP)

EFFECTIVE  
FILTER BAG  
SHAKER

FILTERS NEVER  
NEED CLEANING  
AS THE CANISTER  
FILLS.

OPTIONAL HEPA  
FILTER WITH  
CONDITION  
INDICATOR

OVERHEAD  
CRANE LIFT  
HOOKS

4" NPT  
INLET WITH  
INTERNAL  
WEAR STRIP

29.8 US GAL  
STORAGE DRUM

HEAVY DUTY  
8" FRONT  
WHEELS

26" DIAMETER  
BAGHOUSE FILTER

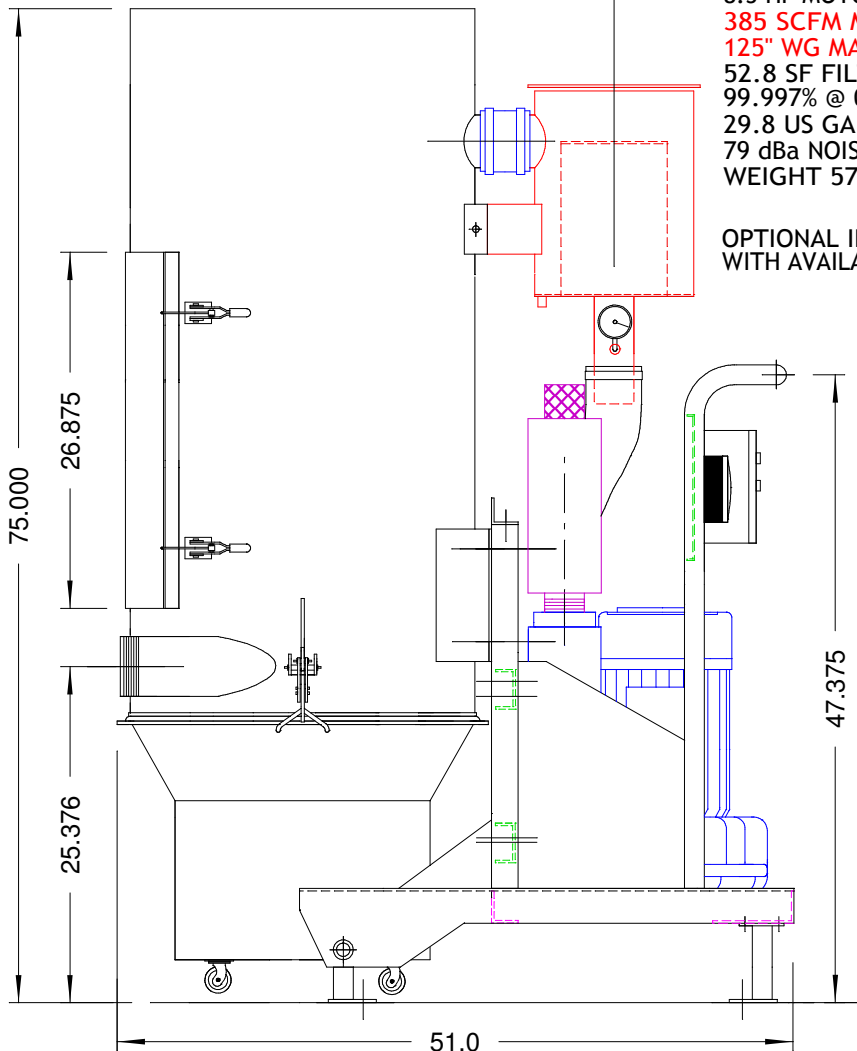

### SPECIFICATIONS:

8.5 HP MOTOR (VOLTAGE TO SUIT)  
**385 SCFM MAX**  
**125" WG MAX VACUUM**  
52.8 SF FILTER BAGS  
99.997% @ 0.4 MICRON EFFICIENT  
29.8 US GALLON STORAGE DRUM  
79 dBa NOISE LEVEL  
WEIGHT 570 LBS

OPTIONAL INLINE FILTER  
WITH AVAILABLE HEPA UPGRADE

VACUUM GAUGE  
& RELIEF VALVE  
STANDARD

NEMA 12  
STARTER PANEL  
& DP GAUGE

HEAVY DUTY ALL  
STEEL FRAME

8.5 HP  
QUIET, DEPENDABLE  
VACUUM PRODUCER

EFFECTIVE, BUILT-IN  
SILENCER

LOCKABLE  
5" SWIVEL CASTERS

			DATE:	OCT 2005	DUROVAC INDUSTRIAL VACUUMS BRAMPTON, ONT 888-330-3365
			DRAWN BY:	KRW	
			SCALE:	N.T.S.	
00	03 JUN 04	ISSUED FOR REVIEW	DRAWING No.	Rev.	<b>DuroVac</b> <b>DVR8553c</b> CONTINUOUS DUTY VACUUM SYSTEM
No.	DATE	REVISIONS	502024 DO1	00	