

FEATURES:

- HUGE 66 SQ FT FILTER HANDLES ULTRA-FINE DUST
- MOBILE PLATFORM OR HOOK UP AS A CENTRAL VAC
- SUPER QUIET! JUST 83 dBa
- CONTINUOUS DUTY BLOWER
- 350 ACFM @ 12" Hg.

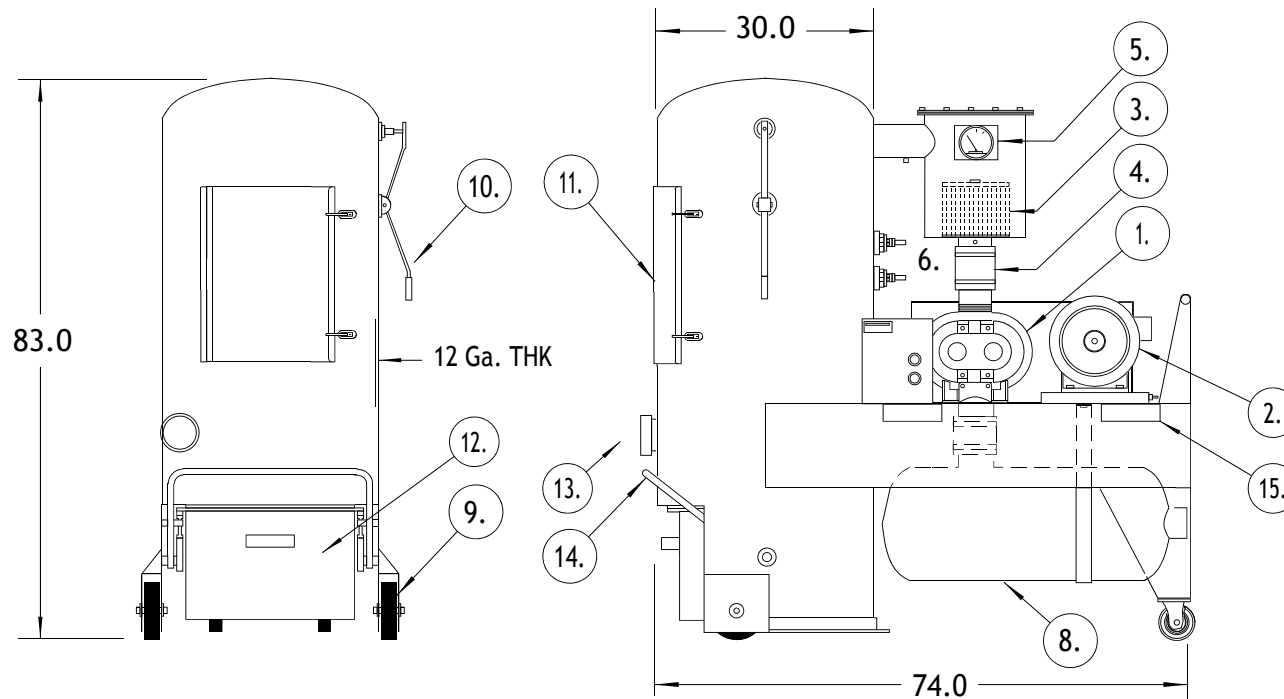
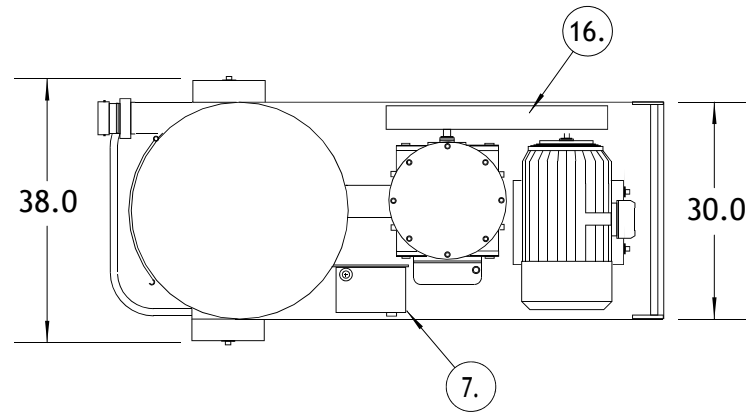

FOR APPROVAL CERTIFIED

PROJECT:

LEGEND:

1. SUTORBILT 5LP P.D. BLOWER
2. 15 HP MOTOR, VOLTAGE TO SUIT
3. INLINE FILTER PROTECTS AGAINST MAIN FILTER DUST LEAKS
4. VIBRATION SLEEVE
5. FILTER CONDITION INDICATOR
6. VACUUM RELIEF VALVES
7. NEMA 12 STARTER C/W 50 FT CORD
8. OVERSIZE EXHAUST SILENCER
9. EXTRA HEAVY-DUTY 10" CASTERS
10. EXTERNAL BAG SHAKER HANDLE
11. EASY ACCESS SERVICE DOOR
12. 4.0 CU FT DIRT CAN ON WHEELS
13. 4.0" INLET
14. DIRT CAN HANDLE
15. 6" x 3" FORKLIFT CHANNELS
16. BELT GUARD

09 Jun 00	ISSUED FOR REVIEW	KW
DATE	PARTICULARS	BY

**NORTHWIND AIR SYSTEMS
BRAMPTON, ONTARIO**

15 Hp DuroVac

SCALE: NONE PAGE 1 OF 1

DRAWING No. **D203067** Rev. **01**