

FEATURES:

- HUGE 66 SQ FT FILTER HANDLES ULTRA-FINE DUST
- MOBILE PLATFORM OR HOOK UP AS A CENTRAL VAC
- SUPER QUIET! JUST 85 dBa
- CONTINUOUS DUTY BLOWER
- 580 ACFM @ 14" Hg.

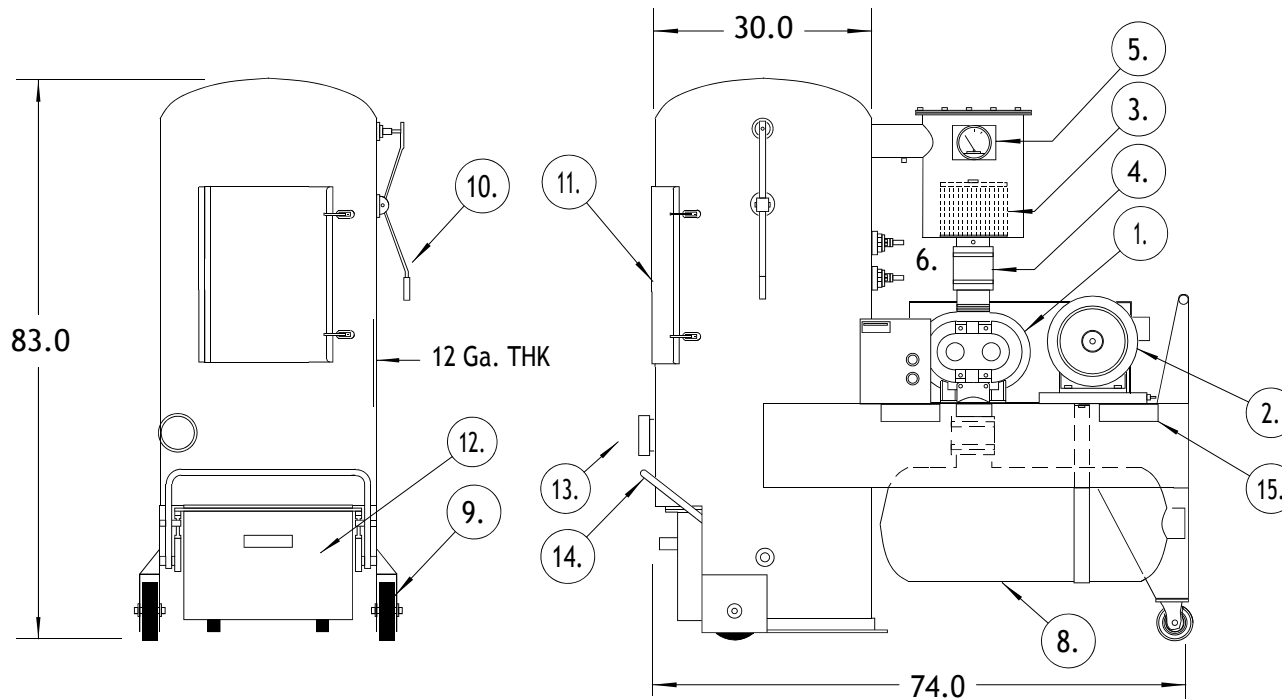
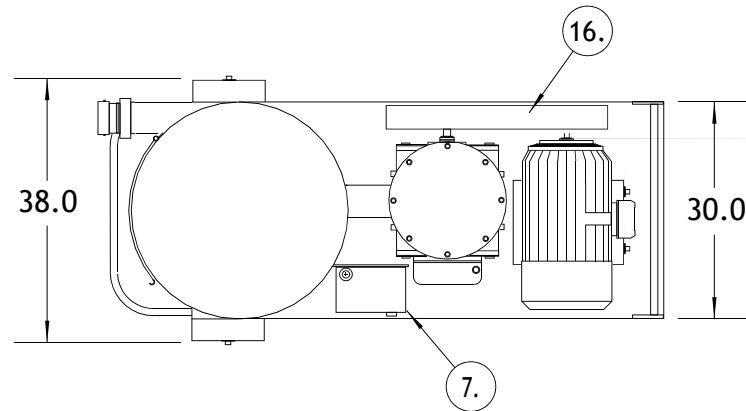

FOR APPROVAL CERTIFIED

PROJECT:

- LEGEND:
1. SUTORBILT 5L P.D. BLOWER
 2. 25 HP MOTOR, VOLTAGE TO SUIT
 3. INLINE FILTER PROTECTS AGAINST MAIN FILTER DUST LEAKS
 4. VIBRATION SLEEVE
 5. FILTER CONDITION INDICATOR
 6. VACUUM RELIEF VALVES
 7. NEMA 4 STARTER & 50' CORD
 8. CUSTOM TUNED EXHAUST SILENCER
 9. EXTRA HEAVY-DUTY 10" CASTERS
 10. EXTERNAL BAG SHAKER HANDLE
 11. EASY ACCESS SERVICE DOOR
 12. 4.0 CU FT DIRT CAN ON WHEELS
 13. 4.0" NPT INLET
 14. DIRT CAN HANDLE
 15. 6" x 3" FORKLIFT CHANNELS
 16. BELT GUARD

16/05/01	ISSUED FOR REVIEW	KW
DATE	PARTICULARS	BY
NORTHWIND AIR SYSTEMS BRAMPTON, ONTARIO		
<h1>25 Hp DuroVac</h1>		
SCALE:	NONE	PAGE 1 OF 1
DRAWING No.	D203069	00
		Rev.