

**FEATURES:**

- HUGE 66 SQ FT FILTER HANDLES ULTRA-FINE DUST
- MOBILE PLATFORM OR HOOK UP AS A CENTRAL VAC
- SUPER QUIET! JUST 85 dBa
- CONTINUOUS DUTY BLOWER
- 650 ACFM @ 16" Hg.

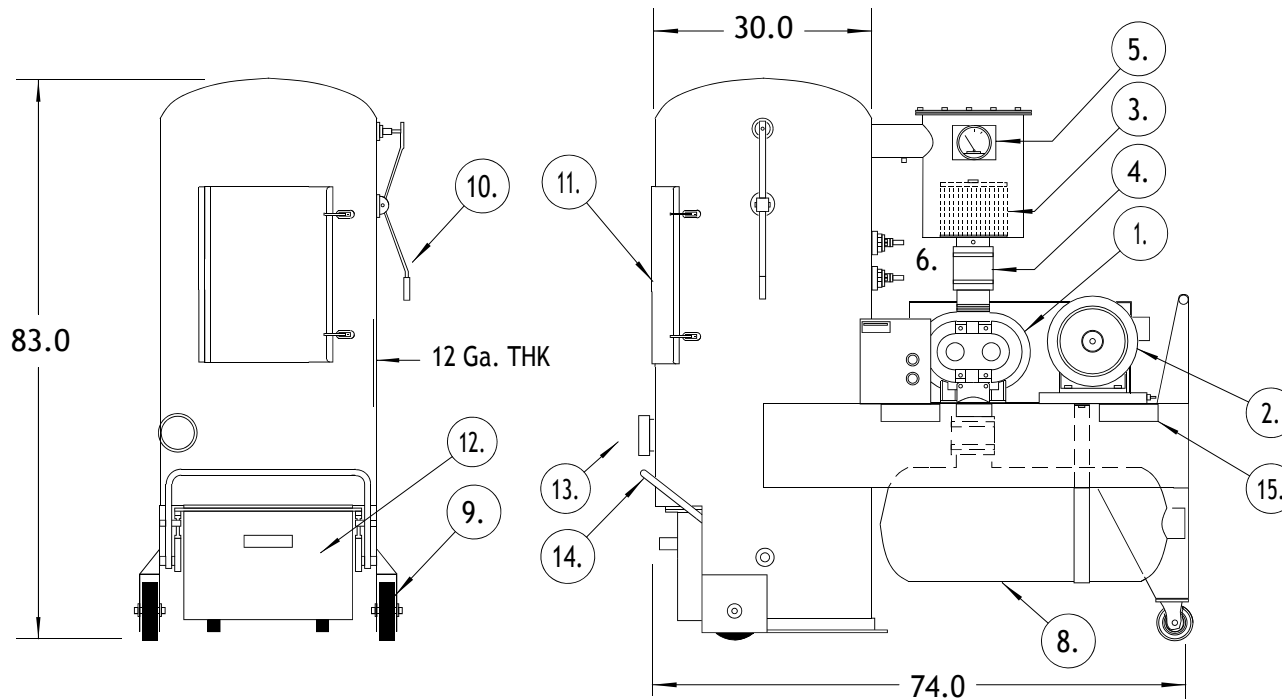
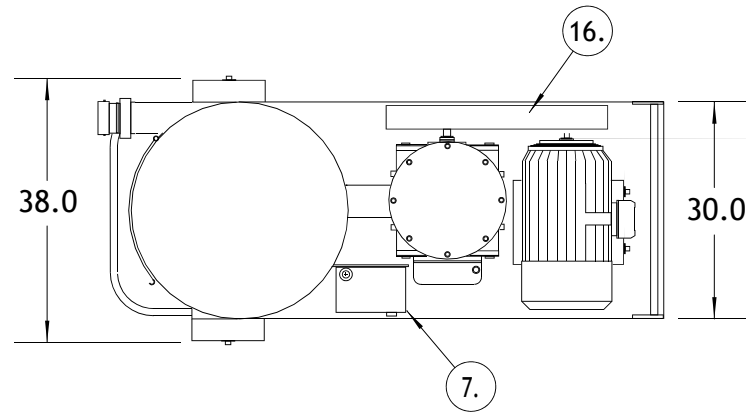

FOR APPROVAL     CERTIFIED

PROJECT:

- LEGEND:
1. SUTORBILT 6M P.D. BLOWER
  2. 30 HP MOTOR, VOLTAGE TO SUIT
  3. INLINE FILTER PROTECTS AGAINST MAIN FILTER DUST LEAKS
  4. VIBRATION SLEEVE
  5. FILTER CONDITION INDICATOR
  6. VACUUM RELIEF VALVES
  7. NEMA 4 STARTER & 50' CORD
  8. CUSTOM TUNED EXHAUST SILENCER
  9. EXTRA HEAVY-DUTY 10" CASTERS
  10. EXTERNAL BAG SHAKER HANDLE
  11. EASY ACCESS SERVICE DOOR
  12. 4.0 CU FT DIRT CAN ON WHEELS
  13. 4.0" NPT INLET
  14. DIRT CAN HANDLE
  15. 6" x 3" FORKLIFT CHANNELS
  16. BELT GUARD

16/05/01	ISSUED FOR REVIEW	KW
DATE	PARTICULARS	BY
NORTHWIND AIR SYSTEMS BRAMPTON, ONTARIO		
<h1>30 Hp DuroVac</h1>		
SCALE:	NONE	PAGE 1 OF 1
DRAWING No.		Rev.
D203070	00	