

PROJECT:

FOR APPROVAL

CERTIFIED

# DUROVAC MODEL PL200p PORTABLE VACUUM SYSTEM

**STANDARD FEATURES:**

1. 400 ICFM @ 16" Hg. CONTINUOUS
2. SUTORBILT 6M VACUUM PRODUCER
3. 20 HP LEESON MOTOR
4. FOUR (4) CARTRIDGES WITH TOTAL 244 SF FILTER AREA
5. **99.9% AT 1.0 MICRON, STANDARD**
6. AUTOMATIC PULSE CLEANING "ON DEMAND"
7. 45.4 SF INLINE FILTER, STANDARD
8. 40 CF MATERIAL STORAGE
9. SILO TYPE, ABRASION RESISTANT INLET
10. **CUSTOM TUNED SILENCER, UNDER 85 DBA @ 3FT!**

FOUR (4) CARTRIDGE FILTERS  
244 SQ FT SURFACE AREA

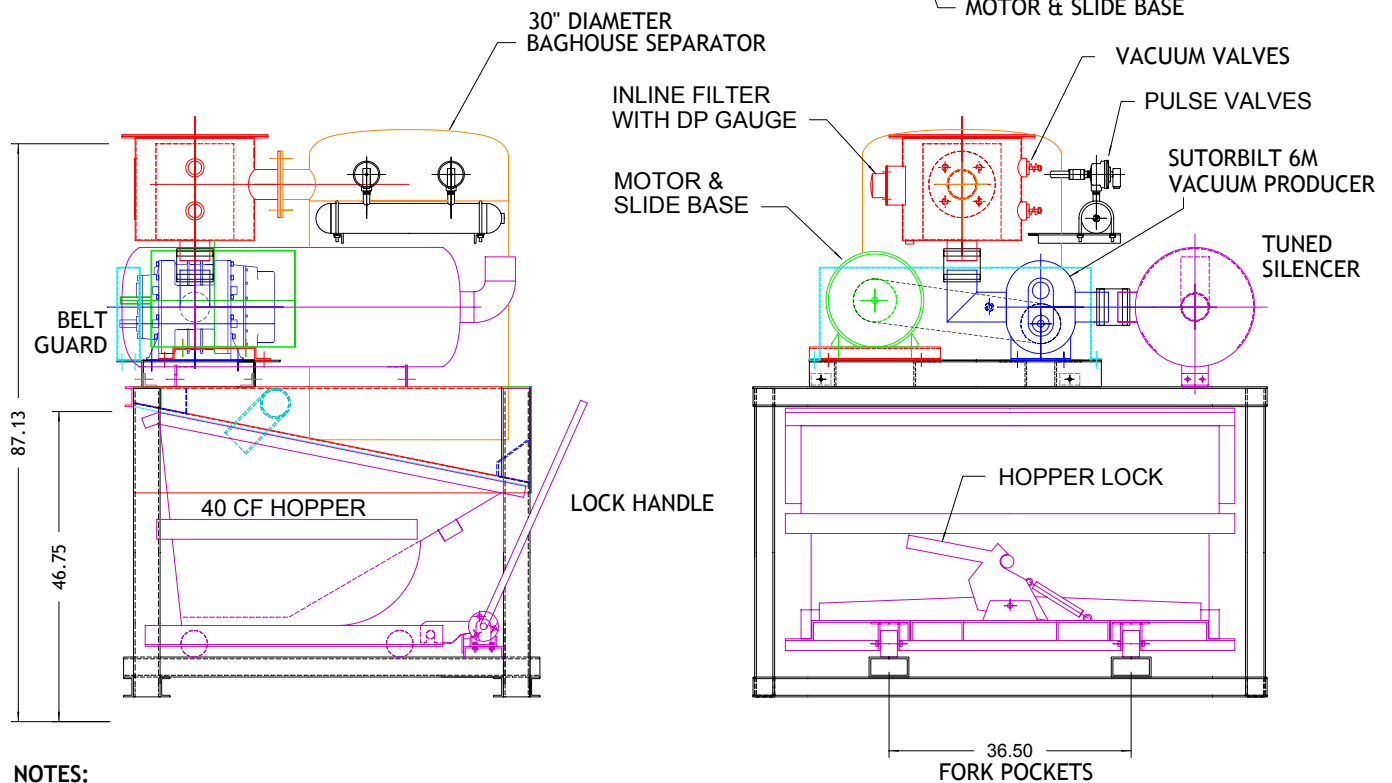
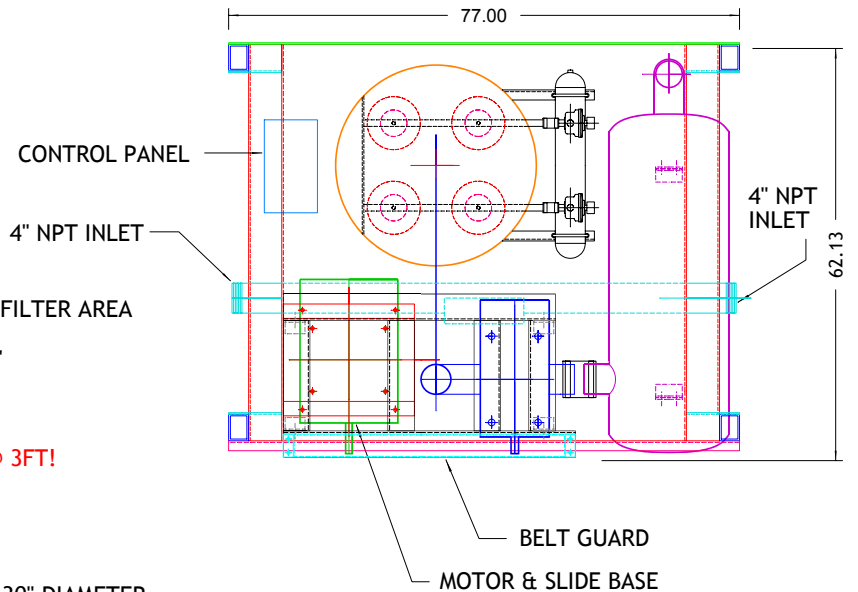

**NOTES:**

1. SUITABLE FOR WET AND DRY PICKUP
2. EXPECT 125 - 175 LBS/MIN PICKUP WITH 2.5" HOSE 25 FT LONG
3. WILL SUPPORT A FIXED PIPE NETWORK UP TO 400 FT LONG WITHOUT MODIFICATION
4. PAINTED PRIME BASE COAT AND TWO TOP COATS OF ENAMEL

**WARNING: VACUUM PRODUCERS THAT CLAIM TO ACHIEVE 18" Hg. CAN \*NOT\* MAINTAIN VACUUM AT THAT LEVEL WITHOUT OVERHEATING!  
ENSURE YOU ASK FOR A WRITTEN PERFORMANCE GUARANTY THAT SPECIFIES 1 HOUR SEALED RUN TIME**

NORTHWIND AIR SYSTEMS BRAMPTON, ON 888-330-3365	01			DATE:	DRAWING No.	Rev.
	00	10 DEC 02	FOR REVIEW	DRAWN BY: KRW	<b>ND2002158</b>	<b>00</b>
	Rev.	Date		SCALE: NTS	PAGE 1 OF 1	